

# PWM10CC | PWM30CC



RENOGY Pulse Width Modulation Solar Charge Controller Manual



14288 Central Ave., Suite A Chino, CA 91710  
1-800-330-8678

## 1. Quick Start Instructions

This section provides a brief overview of how to begin using your solar charge controller. It is recommended that each user review the entire manual to ensure the best possible performance as well as maximize years of worry-free service. It is highly recommended that the connections be made in the following steps provided:

1. Mount the charge controller onto a clean, vertical flat surface. It is very important to allow enough space both above and below the charge controller to ensure maximum airflow.
2. **Connect the Battery**  : After proper mounting is established, connect the battery or battery bank to the charge controller battery terminals. Be careful not to switch the polarities of the battery and do not allow the bare wires to touch the metal casing of the charge controller. As soon as the battery is connected to the charge controller, the device will **power automatically** and will light green when the battery voltage is in the right range.
3. **Connect the Solar Panel(s)**  : Connect the solar extension cables into the charge controller PV terminals. The green LED indicator will light up if there is enough sunlight. Make sure the solar module(s) voltage and current do not exceed the ratings of the charge controller.
4. **Connect the DC Loads (optional)**  : Connect 12VDC (12V systems) or 24VDC (24V systems) loads to these terminals. The maximum rated current is 10 amps for the PWM10CC and 30 amps for the PWM30CC. However, for safety, it's recommended that the loads do not exceed 80% of this rating. If the orange or red LED battery indicator light turns on, the battery capacity is low and needs to be charged before using any of the connected loads again. **Do not connect devices such as power inverters, high power DC motors/pumps or other DC electronics with heavy electrical load that exceed the charge controller ratings.**
5. After all connections are made as shown in **Fig. 1**, the charge controller will now be providing charge to your battery or batteries. To test the system for proper connections, press the SET button on the charge controller until you see number **6.** (6 "Dot") or **7.** (7 "Dot"). See **Table 1** for description of each work mode.

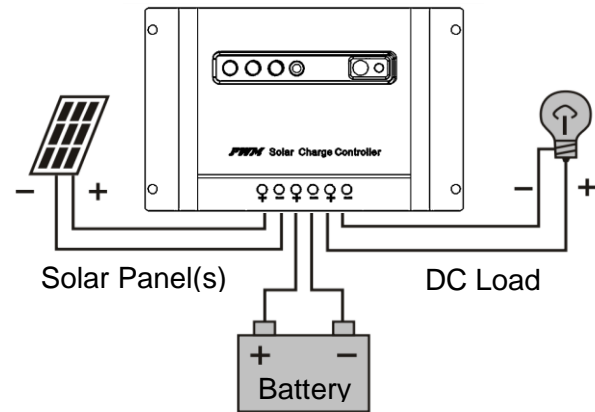

**Figure 1.** Wiring diagram



## 2. Load Control Options

Press and hold the SET button for about **5 seconds** until the display starts flashing. Press the SET button once again to select the one of the desired control options shown in **Table 1**. When done selecting the desired option, wait until the display stops flashing. The load LED will come on, which will indicate that you have selected an option. The controller requires about 10 minutes of continuous transition values before it starts working properly. These constraints avoid false transitions due to lighting or shading.

10A	30A	Description of Work Mode	10A	30A	Description of Work Mode
0	0	Dusk-to-Dawn, light will be on all night	10	0.	Light will be on for 10 hours after sundown
1	1	Light will be on for 1 hour after sundown	11	1.	Light will be on for 11 hours after sundown
2	2	Light will be on for 2 hours after sundown	12	2.	Light will be on for 12 hours after sundown
3	3	Light will be on for 3 hours after sundown	13	3.	Light will be on for 13 hours after sundown
4	4	Light will be on for 4 hours after sundown	14	4.	Light will be on for 14 hours after sundown
5	5	Light will be on for 5 hours after sundown	15	5.	Light will be on for 15 hours after sundown
6	6	Light will be on for 6 hours after sundown	16	6.	Manually turn on/off output with SET button
7	7	Light will be on for 7 hours after sundown	17	7.	Test mode:
8	8	Light will be on for 8 hours after sundown			(1) Light turns on after no sunlight detected
9	9	Light will be on for 9 hours after sundown			(2) Light turns off after sunlight detected

**Table 1.** Load control options

## 3. LED Indicators

Icon	Description
	<u>Green ON:</u> Solar power is charging the battery <u>Green BLINKING:</u> The system is over voltage
	<u>Green ON:</u> Battery level is in the right range <u>Green SLOWLY FLASHING:</u> Battery level is full <u>Orange ON:</u> Battery level is low <u>Red ON:</u> Load cut-off
	<u>Orange ON:</u> The load output is on <u>Red SLOWLY FLASHING:</u> Overload* <u>Red BLINKING:</u> Load is short-circuit*

**Table 2.** LED indicators

**\*Note:** The load amps is 1.25 times of the rated current for 60 seconds or the load amps is 1.5 times the rated current for 5 seconds. The output will shut off once there is an overload or short circuit. Disconnect all of the equipment and then wait a few seconds before reconnecting everything. Press the SET button and the controller will resume working after approximately 10 seconds, or in some instances, it may take a few moments longer.

## 4. Troubleshooting

### 1. *Charging LED indicator turns off during the daytime*

- a. The green LED should be ON during the daytime.
- b. Check to make sure the correct battery is being used.
- c. Check all wiring connections to make sure they are in their designated locations and make sure that there are no loose connections.
- d. Measure the PV array open-circuit voltage and confirm it is within its normal limits.
- e. Measure the PV voltage and the battery voltage at the controller terminals. If the voltage at the terminals is within proper specifications, the PV array is charging the battery properly. If the PV voltage is within specifications to the open circuit voltage rating of the panels, but the battery voltage is low, the charge controller may not be charging the battery and it may be damaged.

### 2. *Charging LED indicator is blinking*

- a. Check the operating conditions to confirm that the voltage is higher than the specifications. Consider the temperature compensation of the charge controller's PWM set point. For example, at 0°C the charge controller will regulate at about 15 volts.
- b. Check all wire connections in the system to ensure they are in the correct location. Check for loose wires.

### 3. *Red load LED indicator is blinking or flashing (load not operating properly)*

- a. Check the load to make sure it is on and make sure the fuses are not blown.
- b. Check connections to the load, other controllers, and battery. Make sure the voltage drops in the system wires are not exceeded.
- c. If the LED indicator is blinking and there is no output, check the load for short-circuit. In case of short-circuit, disconnect the load and press the SET button, and wait for approximately 30 seconds for the charge controller to resume working again.
- d. If the LED indicator is still flashing and there is no output, check the load to make sure the load is not over the rated power. Reduce the load and press the SET button. Then wait for approximately 30 seconds for the charge controller to resume working again.

## 5. Inspection and Maintenance

It is highly recommended that each user inspect the charge controller at least once per year to ensure longevity and optimal performance. Please follow this procedure:

1. Confirm that the correct battery type has been used.
2. Confirm that the current levels of the solar array and load do not exceed the controller ratings.
3. Inspect for loose, broken, or burnt wire connections and replace them if needed. Make sure all terminals are tightened.
4. Press the SET button until number 16 is displayed to verify the lights are working properly.
5. Inspect for dirt, insects, and corrosion on the charge controller.
6. Check to make sure there is still enough space around the charge controller for maximum airflow.
7. Check to make sure the charge controller functions and LED indicators are working properly.
8. Make sure the PV array is clean and remove any debris.
9. Make sure all of the railings and PV bolts are tightened.

## 6. Charge Controller Specifications

### Controller Parameters

Description	10A Parameters	30A Parameters
Nominal System Voltage	12V/24V Auto recognition	12V/24V Auto recognition
Rated Charge Current	10A	30A
Rated Load Current	10A	30A
Max. Solar Input Voltage	42V	42V
Max. PV Input Power	120W (12V), 240W (24V)	360W (12V), 720W (24V)
Self-consumption	< 6mA	< 6mA
Operating Temperature	-35°C to + 55°C	-35°C to + 55°C
Temp. Compensation	-30mV/°C (12V), -60mV/°C (24V)	-30mV/°C (12V), -60mV/°C (24V)
Terminals	10 AWG	10 AWG
25% Current Overload	1 Minute	1 Minute

**Table 3.** Electrical Parameters

**Note:** For safety, do not exceed 80% of charge controller current rating. This rating should be based on total short-circuit current of the solar panels.

### Battery Parameters

Description	Parameter
Load Disconnect	11.1V (12V), 22.2V (24V)
Load Reconnect	12.6V (12V), 25.2V (24V)
Equalization Voltage (30 minutes)	14.6V (12V), 29.2V (24V)
Boost Voltage (30 minutes)	14.4V (12V), 28.8V (24V)
Float Voltage	13.6V (12V), 27.2V (24V)
Battery type	Sealed Lead Acid and Flooded

**Table 4.** Battery Parameters